

**Warning:** Jordan Valve Temperature Regulators must only be used, installed and repaired in accordance with these Installation & Maintenance Instructions. Observe all applicable public and company codes and regulations. In the event of leakage or other malfunction, call a qualified service person; continued operation may cause system failure or a general hazard. Before servicing any valve, disconnect, shut off, or bypass all pressurized fluid. Before disassembling a valve, be sure to release all spring tension.

**Please read these instructions carefully!**

Your Jordan Valve product will provide you with long-term, trouble-free service if it is correctly installed. Spending a few minutes of your time reading these instructions now may save hours of trouble and downtime later.

### Installation

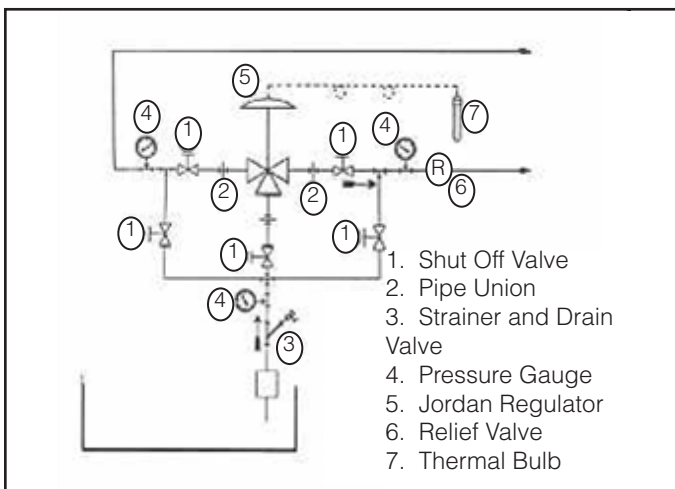

1. To protect the temperature regulator from grit, scale, thread chips, and other foreign matter, all pipe lines and piping components should be blown out and thoroughly cleaned before the valve is installed.
2. Shutoff valves, pressure gauges, and bypass piping should be installed as indicated in the diagram to provide easier adjustment, operation, and testing.
3. In preparing threaded pipe connections, care should be taken to prevent pipe sealing compound from getting into the pipe lines. Pipe sealing compound should be used sparingly, on male threads only, leaving the two lead threads clean. Jordan uses, and recommends, Seyco #2415 thread sealer Teflon ribbon.
4. A line strainer should be installed on the inlet side of the temperature regulator to protect it from grit, scale and other foreign matter. A 20-mesh Monel screen is usually suitable. Line strainers are available from Jordan Valve.
5. Install the regulator in the highest horizontal line of piping to provide drainage for inlet and outlet piping, to prevent water hammer, and to obtain faster regulation.
6. The flow arrow on the regulator body must be pointed

7. in the direction of flow. The valve may be installed vertically or horizontally without affecting its operation. For best control, 3' 0" straight sections of pipe should be installed on either side of the valve.
8. To minimize condensation in hot vapor lines, upstream and downstream piping near the regulator should be insulated.
9. For injection heating applications, the regulator should be installed above the maximum water level in the tank, or a check valve should be installed to prevent water from backing up into the regulator.
10. For best regulation, the temperature regulator should be installed as closely as possible to the unit in which the temperature is being controlled.
11. On steam control applications, install a steam trap of sufficient capacity to drain the coil or condenser. Be sure to have a good fall to the trap, and no back pressure. Best control is obtained when the coil or condenser is kept dry.

### Bulb Installation

The thermal system is hermetically sealed unit consisting of a sensing bulb, capillary tubing, protective armor, and actuator assembly. This unit contains the thermostatic charge that operates the temperature regulator. Please do not tamper with it. In case the charge is lost, the thermal system must be replaced as a complete unit. It is not repairable in the field and must be returned to the factory for repairs.

1. *Correct Installation* - For effective temperature control, correct installation of the sensing bulb is essential. For best results, the bulb should be installed at a point of true representative temperature and where there is good circulation. A thermometer or other temperature sensing device (if used) should be placed as close as possible to the sensing bulb of the regulator.
2. Handle the capillary and armor carefully so they are not crushed, kinked, or twisted. A bend of 4½" radius or larger is recommended.
3. *Horizontal Mounting* - when the bulb is to be mounted horizontally, it must be turned so that the work TOP (stamped on the adapter) faces upward.
4. *Vertical Mounting* - No special precaution is required when the bulb is mounted vertically pointing down.
5. *Inverted Mounting* - A special capillary is required if the tip of the bulb will be higher than the capillary

end. The temperature regulator equipped with a standard capillary will not function properly in an inverted position.

6. *Insertion* - For accurate control, the entire length of the bulb should be inverted. Avoid locating a bulb in the direct path of steam or water. Never lay the bulb on the bottom of a tank. Approximately 8" is sufficient distance from the source of heat or coolant to the sensing bulb.
7. *Pipeline Mounting* - When installing the sensing bulb in piping, be sure that the pipeline is at least twice the diameter of the sensing bulb so that free flow is obtained around the bulb.
8. *Finned Bulbs* - Finned bulbs should be installed at right angles to the air movement. Good circulation is required to sense the average temperature.
9. When the bulb is installed at a point higher than the regulator itself, the range will probably be somewhat lowered. Conversely, the range will be raised if the bulb is installed below the regulator.

---

## Trouble Shooting

---

### Erratic Control:

- An oversized valve causes cycling or hunting. An undersized valve causes temperature to drop under peak loads. Recalculate required size from Jordan Catalog TCV.
- Inlet pressure may be low.
- Steam traps downstream may need reconditioning.
- Foreign matter may be lodged in valve seats.
- Valve stroke may be out of adjustment.

### Underheating:

- Be sure that by-pass Seats are fully open.
- Be sure that inlet pressure is adequate.
- Clean line strainer screens.
- Clean steam traps and be sure that they are working properly. If the return line from the trap is cool, the steam coil may be clogged.

### Overheating:

- Overheating is often caused by foreign matter holding the by-pass seats in the open position. Inspect and clean seats or replace them.
- Check stroke adjustment.
- Check for damage or failure of the thermal system.

### Undercooling or Overcooling:

- Be sure that coolant is circulating properly and that all steps have been taken as indicated for underheating or overheating in items 2 and 3 above.

### Thermal System Failure:

Thermal system failure is usually indicated by failure of the regulator to respond to temperature changes, and when all other trouble shooting steps have failed to correct the problem. The adjusting spring will hold a direct acting valve OPEN or reverse acting valve CLOSED.

The thermal system can be tested by placing the sensing bulb in a container which can be quickly heated with steam

or hot water, or cooled with cold water or crushed ice. Observe the valve stem while alternately heating and cooling the bulb. If the stem does not move, it is likely that the thermal system has lost its fill. The thermal system is hermetically sealed and cannot be repaired in the field. It must be replaced by a complete, new thermal system or the old unit must be repaired at the factory.

---

## Start Up

---

1. Close the inlet and outlet shut-off valves.
2. Slowly open the by-pass, and begin heating or cooling action.
3. Fully open the inlet shut-off valve. Then slowly open the outlet shut-off valve.
4. Close the by-pass valves when the approximate temperature is reached.
5. Allow approximately 30 minutes to reach stable operation before attempting to adjust the temperature setting (and after each new setting).
6. To change the control temperature, rotate the adjusting wheel downward to decrease and upward to increase the temperature setting.

---

## Valve Seats

---

### A. Disassembly

The valve seats in all Jordan regulators are lapped to a light band flatness. Maintaining such tolerances is of great importance for your assurance of excellent control and tight shut-off. Do not use metallic objects in removing the seats. Care in handling is important.

1. Close shut-off valve on each side of the regulator.
2. Remove the regulator from the line.
3. Note the scribe line on the side of the valve body and the caps. Secure one of the outlet cap hexes (1) in a vise. Remove the cap screws (2) from the other cap and lift the cap straight up. Please note that there is an index pin secured in the valve cap that fits into the index pin hole in the valve plate (3).
4. Next remove the valve plate and place it on the bench with the lapped surface up. You will notice that there is also a locating pin which aligns the valve plate with the disc guide. The scribe line on the outside of the valve cap and the valve body indicates that this locating pin should be on this side.
5. Now remove the valve disc (4) and the disc guide (5), placing the valve disc on the bench with the lapped surface up. Finger-tip pressure should be sufficient to remove these parts.

**NOTE:** It is imperative that the disc pin is not rotated in disassembly, cleaning, or reassembly, since this affects the stroke adjustment of the valve.

IMPROPER HANDLING OF THE SEATS WILL RESULT IN LEAKAGE OR IMPROPER CONTROL

6. Clean all parts of the body and cap with a good quality solvent. The valve disc and the valve plate may

then be cleaned. Place a 4/0 polishing cloth or jeweler's cloth on a smooth, flat surface, and polish the lapped surfaces. If the parts are badly scarred, do not attempt to re-lap them, but return them to the factory for repair or replacement.

7. A 0.005 feeler gauge should be used to check the clearance between the valve disc and the disc guides. If the clearance is less than 0.005", clean the disc guides with a smooth file.

## B. Reassembly

1. Place the disc guide in the body bore with the index pin on the same side as the scribe line on the valve body.
2. Place the disc in the aperture of the disc guide and engage the disc pin.
3. In placing the plate in the body, notice that the index pin hole in the lapped surface of the plate engages the index pin of the disc guide.
4. In replacing the valve cap, notice that there is an index pin secured in the valve cap. This index pin must be engaged in the index pin hole of the valve plate.
5. To properly align the valve cap, a slight rotation is normally sufficient to align the index pin with the index pin hole in the downstream side of the valve plate.
6. Tighten the cap screws uniformly, being cautious not to apply too much torque. See table on page 4 for torque recommendations.

REPEAT DISASSEMBLY AND REASSEMBLY PER "A" AND "B" ABOVE FOR SECOND SET OF SEATS.

## Disc Pin

1. Remove the valve disc and valve plate (3, 4) following the procedure outlines under "Valve Seats" above.
2. Loosen the stem connector nut and bolt (18, 19) and remove connector assembly (17).
3. Back out the four allen headscrews (50) which will allow the valve body (49) to be separated from the valve yoke (20).
4. Loosen the disc pin nut (7) and rotate the disc pin (6) counterclockwise, pulling valve stem (16) upward while doing so. Do not remove the valve stem completely but raise it sufficiently so that the disc pin may be removed by pulling up and out.
5. Replace the disc pin so that the case "B" on the disc pin faces up and is on the normally open side of the body and reassemble in reverse order following the procedures outlines under VALVE SEATS and STROKE ADJUSTMENT.

## Packing

1. Remove connector assembly (17).
2. Remove both packing flange nuts (15).
3. Remove packing gland (12) and packing follower (11).
4. Should packing spring (9) not eject packing set (10), a slight amount of downstream pressure might be necessary to remove the packing set.
5. Remove packing retainer (13) and packing spring (9).

6. Clean packing bore with solvent and blow out thoroughly.
7. Assemble in reverse order and tighten packing nut (15) so that packing follower (11) bottoms out on top of valve body.
8. Engage valve stem (16) and actuator stem (22) with connector. Tighten connector nut and bolt. No stroke adjustment is required.

## Valve Stroke Adjustment

If the temperature regulator requires a stroke adjustment after maintenance on one of the above points, follow these procedures:

1. Remove the cooling line seats (normally closed) as outlined above in "Valve Seat Disassembly" section.
2. Make sure that the actuator stem (22) is stroked fully upward by the spring (27).
3. Loosen the disc pin locknut (7).
4. Loosen the stem connector bolt (18) only enough to allow the stem (16) to rotate. DO NOT remove the stem connector (17). Proper positioning of the valve stem and actuator stem must be maintained during adjustment of seats.
5. Orifices on the disc and plate must be in perfect alignment in the full open position of the by-pass seats. Adjust the positioner of the disc on the plate by rotating the valve stem until the seats are in perfect alignment in the fully open position.

## Valve Stroke Adjustment

1. The thermal system is hermetically sealed unit consisting of a sensing bulb, capillary tubing, protective armor, and actuator assembly. This unit contains the thermostatic charge that operates the TCV. Please do not tamper with it. In case the charge is lost, the thermal system must be replaced as a complete unit. It is not repairable in the field and must be returned to the factory for repairs.
2. The thermal system is easily removed in the field by releasing the spring 927) compression (by rotating the adjusting wheel (24) downwards and removing the four filister head actuator screws (30). Do not remove the adapter plate (31). The valve stroke adjustment will not be affected if the steps are followed carefully.

## Thermometer

If your TCV is equipped with a dial thermometer, it can be re-calibrated by turning the calibrator screw slightly, or removing the needle and replacing it while checking the thermometer as it is also hermetically sealed with the thermal system.

Torque Values (in.-lbs.)		
Valve Size 1½" - 2"	Valve Body Material	
	Bronze	Carbon Steel, Stainless Steel, Ductile Iron
	140	200

# Illustration and Parts List

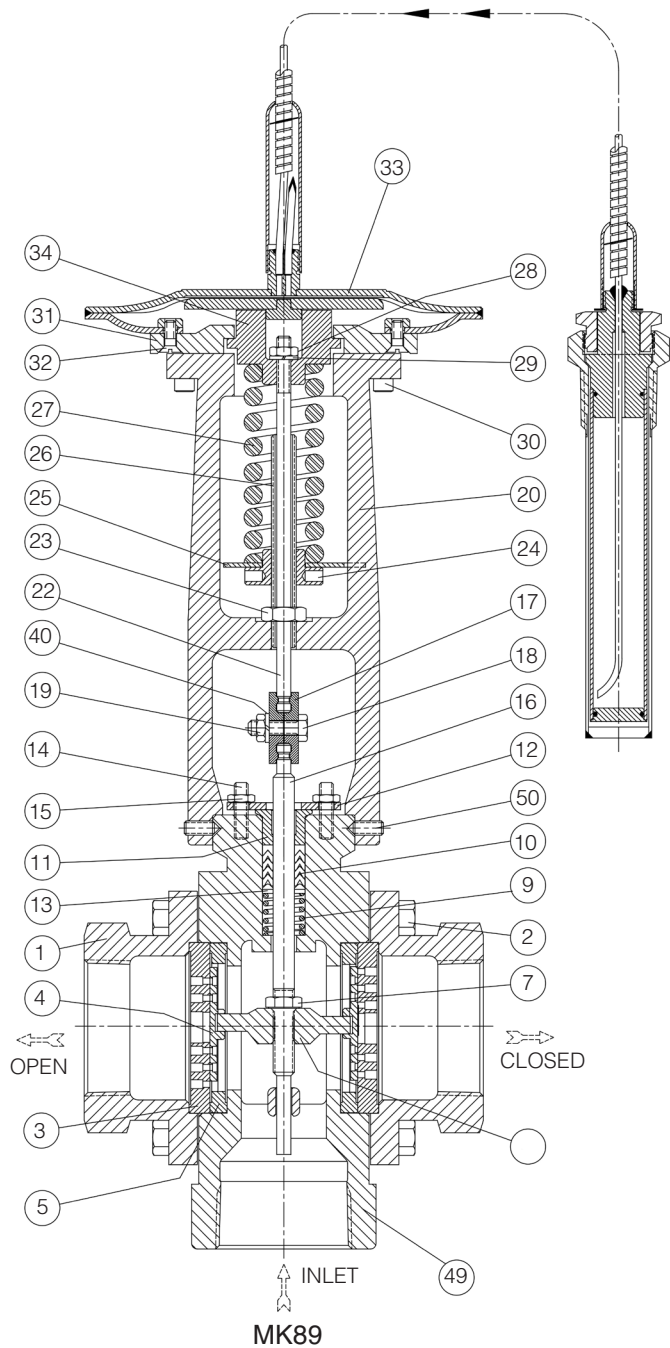

Item	Description	Qty.	Item	Description	Qty.
1	Cap	2	21	Name Plate	1
2	Cap Bolts	12	22	Actuator Stem	1
*3	Plate	2	23	Locknut (Adjusting Wheel)	1
3A	Index Pins (not shown)	4	24	Adjusting Wheel	1
*4	Disc	2	25	Spring Washer	1
*5	Disc Guide	2	26	Adjusting Post	1
*6	Disc Pin	1	27	Spring	1
7	Disc Pin Nut	1	28	Nut	1
9	Spring (Packing)	1	29	Lockwasher	1
*10	Packing	1	30	Actuator Screw	4
11	Packing Follower	1	31	Adapter Plate	1
12	Packing Flange	1	32	Adapter Plate Screw	4
*13	Packing Retainer	1	33	Actuator	1
14	Packing Stud	2	34	Stroke Stop	1
15	Nut	2	46	Chain	1
16	Stem	1	40	Stem Connect Lock Wash	1
17	Stem Connector	1	47	Adjusting Tool	1
18	Stem Connector Bolt	2	48	Cotter Pin	1
19	Stem Connector Nut	1	49	Body	1
20	Yoke	1	50	Yoke Screw	4

\* Recommended Spare Parts

