

PRODUCT OVERVIEW



THE SLIDING GATE SEAT: A BETTER DESIGN

SIMPLE CONCEPT, SUPERIOR PERFORMANCE

You will notice something different in a Jordan valve . . . the sliding gate seat. A remarkably simple concept that offers superior performance and benefits not found in traditional rising stem and rotary valves.

The sliding gate seat is made up of two primary parts: a movable disc and stationary plate with multiple orifices. Together, this seat set achieves levels of performance, reliability and accuracy that are hard to find in other valve designs.

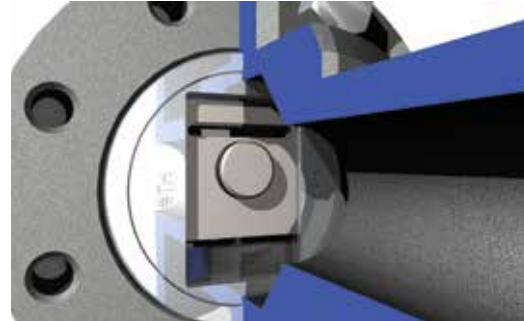

ADVANTAGES

Quiet Operation

Compared to conventional globe and cage designs, the sliding gate seat generates between 5-10dB less noise. You won't find a premium price adder for "low-noise trim!" The sliding gate valve is inherently quieter than other types of valves because:

- The disc and plate remain in constant contact, eliminating the chatter found in globe-style designs
- The straight-through flow passage minimizes turbulence found in globe and rotary designs, a prime cause of valve noise
- The multiple orifices in the plate and disc divide the flow into smaller flow streams resulting in less noise

Size and Weight

As the line size increases, so too does the size and weight of the valve. Because of the short stroke length, a sliding gate valve is typically smaller and lighter weight than a globe/cage style valve.

For the Mark 75 Series control valve, the shipping size, weight, packing waste and costs decrease dramatically due to the wafer style design.



● "Massive" globe or cage style valve

● Smaller, lighter sliding gate wafer-design control valve

Reduced Turbulence

When throttling, the control member of a rotary control valve will direct the flow to the sealing area of the seat, causing premature seat leakage.

The tortuous flow path of a globe style design creates greater turbulence, noise and wear - reducing seat life and compromising control. In flashing or cavitating service, damage to the valve body is common, mitigated only through expensive material upgrades or elaborate trim configurations.

The multi-orifice straight through flow path of the sliding gate reduces turbulence and leads to quieter operation, reduced wear, longer seat life and better control.

For example, when combined with the ultra-compact wafer body design of the Mark 75 Series, erosion of the seats and valve body is virtually eliminated. Dramatic cost savings can be realized.

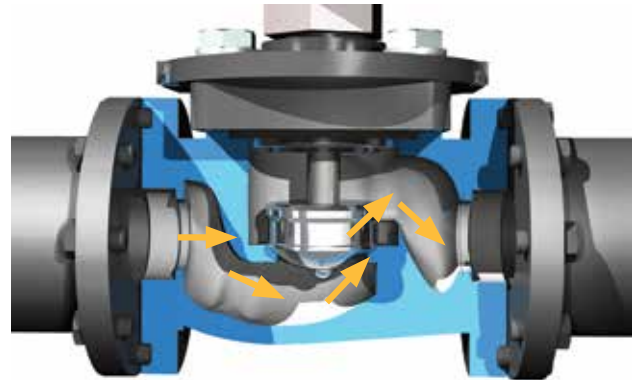

Competitor Valve

The tortuous flow of a traditional globe style valve.

Straight-Through Flow

The seat set is perpendicular to the flow, unlike the traditional globe style design. With straight through flow, the turbulence is reduced and superior trim life is achieved.

The sliding gate design provides exceptional low flow control since the flow works with the seat and not against it. In a typical globe style design, the flow goes underneath the plug, working against the plug. With the sliding gate, the flow pushes the disc against the plate, helping to hold the desired setpoint. This also enables the disc and plate to lap and clean themselves as the valve modulates. The sliding gate design "wears in" instead of wearing out!

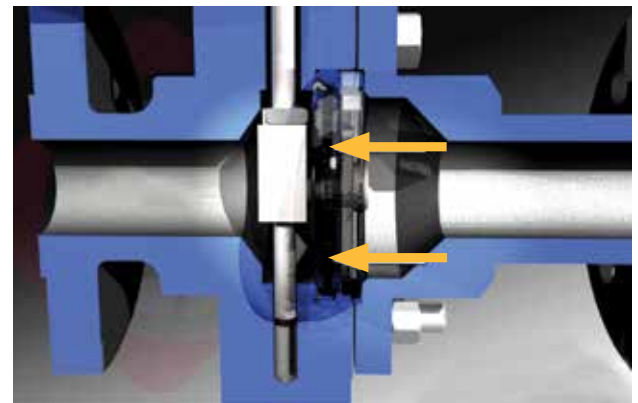

Jordan Valve

The straight-through flow of the sliding gate

Short Stroke, Fast Response

The total stroke length is just a fraction of the equivalent globe valve. In pressure regulators, the stroke length is typically 1/3 that of a globe valve, reducing the amount of droop (deviation from setpoint) in the regulator.

In control valves, the sliding gate allows the use of reduced air consumption and weight minimization. The short stroke reduces packing wear and lengthens the diaphragm life.

THE SLIDING GATE SEAT: A BETTER DESIGN

Seat Coatings

Jordan Valve offers coatings and seat materials to meet almost any application need. Jorcote, our standard seat material, is a proprietary composite coating on Stainless Steel. This material is extremely hard and delivers outstanding performance. Other coatings include Teflon and chrome plating.



Durability

- **Self-Cleaning:** the movement of the sliding gate seats generates a self-cleaning action, with any leak-producing deposits being cleaned off by the sharp shearing action of the disc moving across the plate.
- **Materials:** our proprietary Jorcote seat material is extremely hard (@RC85) and delivers outstanding wear resistance.
- **Multi-orifice:** The multi-orifice design separates erosive flow into smaller, less damaging streams. The erosive forces are dissipated over the numerous slots eliminating the single wear points associated with other valve types and quieter operation.
- **Eliminates Damaging Chatter:** The upstream pressure holds the disc in constant contact with the plate. This prevents the sudden, damaging (and noisy) contact which occurs in some globe designs. The constant contact between the disc and plate actually generate a self-lapping effect which results in less friction and tighter shutoff than when the valve leaves the factory.

Tight Shutoff

The sliding gate design provides an area of closure, not a line of closure. When the valve is closed, the disc and plate are overlapped by 1/32". This area of closure helps reduce the effects of wire draw which is one of the most common causes of seat leakage. What does this mean for you? Less maintenance, downtime and more opportunity to increase yields and profits.

Easy to Maintain

The simple design of the sliding gate valve makes maintenance easy to perform. Disassembly of the valve is very simple, and since the seats are not pressed or screwed into the valve body, they conveniently lift out. Should your flow requirements change, interchangeable Kv's (Cv's) are available in coefficients as low as 0,0007 (0.0008) and as high as 519 (600) (depending on body size).

- **Engineer tested:** Jordan Valve engineers conducted a steam test using 17,2 barg (250 psig) saturated steam. The test was designed so that the valve would fully stroke open and closed each time it was actuated. The pressure drop across the valve was the full 17,2 barg (250 psig). The results were impressive. Our standard Jorcote/Chrome seat combination had less friction after 70,000 cycles than when it was new and the seat leakage was well below ANSI Class IV limits. Jordan Valve engineers are constantly testing and improving our products to ensure optimal high performance in the field.

JORLON DIAPHRAGM

The Jorlon diaphragm extends the life of your regulators and reduces the overall cost of ownership. This diaphragm was developed as an alternative to the standard SST diaphragm.

Jorlon is a proprietary modified PTFE material that positively impacts regulator reliability, performance and service life. It is the standard and preferred diaphragm in most regulator applications and provides many benefits.

- **Chemical Compatibility:** since Jorlon is PTFE based, it is compatible with the same media as Teflon™
- **Temperature Range:** Jorlon can operate up to up to 232°C (450°F) and down as low as -40°C (-40°F)
- **High Pressure Limits:** Jorlon has been tested in excess of our regulators maximum allowable pressures. In some cases, Jorlon can be rated as high as 48,3 bar at 38°C (700 psi at 100°F)
- **Improved Performance:** SST diaphragms, by nature, are rigid and have decreased sensitivity. Jorlon approaches the droop/offset performance seen in true elastomer diaphragms resulting in greater set point accuracy as flow rates change
- **Long Life:** Jorlon has been extensively tested for durability. The diaphragm was tested on both 20,6 bar (300 psi) air and 232°C (450°F) steam with no failures. Jorlon has been cycle-tested over 1,000,000 full stroke cycles with no failures
- **Lower Ownership Costs:** less droop means better accuracy, and better accuracy means better overall performance and productivity. Its long life means less down time to replace a failed diaphragm which translates into higher profits

DISC AND PLATE

OPEN



The disc and plate are shown in the full open position. Note, the straight-through flow. This minimizes flow turbulence, a major cause of poor control, noise and wear in other valve designs.

CLOSED



The disc and plate are shown in the full closed position. The 1/32" overlap assures tight shut-off. The overlap also provides a buffer of extra metal to defeat any fringe erosion or wire drawing.

ABOUT JORDAN VALVE

For more than six decades, companies around the globe have relied on Jordan Valve for their most demanding applications. What makes Jordan Valve different?

- **Innovation:** We have talented people working on teams to design innovative new products and further develop our existing product portfolio to serve our customers.
- **A trusted partner:** We help our customers improve their operational efficiency, reduce risks and increase profitability. Our engineering and sales teams offer solutions and products you can trust.
- **Customer-centric:** Through our unmatched combination of products, engineering, and after-market services, we help our customers achieve tangible results: lower operating costs, optimized performance, prolonged equipment life, mitigated risks and higher productivity.
- **Commitment:** No one wants unscheduled downtime or product failure. At Jordan Valve, we have an unwavering commitment to standards and processes that ensure innovative and reliable product designs.
- **People:** A global network of representatives and distributors stand ready to assist you. Visit us at jordanvalve.com or call +1.513.533.5600.



Jordan valves are extremely reliable requiring very little maintenance and rarely need replacement. We have temperature regulators that have been in service for thirty plus years and probably some longer than that!

- Jordan Valve Customer

JVCV Max Sizing Software

Take the worry out of valve specification. The JVCV Max Sizing Software is available on the Jordan Valve website. By entering just a few parameters, you have the ability to calculate the required Kv (Cv) for your application. Download, print or share the results with anyone.

Quick Ship Program

Our Jordan Valve Quick Ship Program offers you options to get the products you need, when you need them. Many products can be shipped within 5 (five) business days.. Go to our website for the full list of valves available for quick shipment.

Specials

A wide range of body materials, Cvs (Kvs), and pressure range options are available to meet the different service conditions in which our valves may be required to operate. All options are not shown in the Product Overview. For special materials, contact your local Jordan Valve representative.

Rigorous Testing

Every Jordan regulator, temperature regulator and control valve manufactured in our Cincinnati, Ohio facility is thoroughly tested before shipment.

CONTENTS

1



SLIDING GATE REGULATORS

Pressure & back pressure regulators including, self-operated, super high flow, high sensitivity, differential, dome loaded, vacuum, pilot-operated, wafer style

2



TEMPERATURE REGULATORS

Self-operated, high flow, controlled-failure option, ambient temperature, externally piloted and three way mixing/diverting temperature regulators

3



TANK BLANKETING & GAS VALVES

Low pressure, balanced plug, double seated, piloted, internally piloted, high inlet pressure and critical pressure

4



GLOBE-STYLE REGULATING VALVES

Globe valves, air-loaded globe valves, dual inlet and outlet, piloted and liquid pressure regulating valves

5



SLIDING GATE CONTROL VALVES

Wafer style, diaphragm, high flow/high Kv's (Cv's), motor operated, final control element, bellows seal, globe style and three way control valves

6



GLOBE-STYLE CONTROL VALVES

Globe style control valves with single port, quick change, internal flow cavities, along with angle style, rotary and on/off control valves

1

SLIDING GATE REGULATORS

The sliding gate pressure and back pressure regulators are ideal for steam, liquid, and gas media. A variety of regulators are available including self-operated, high flow, differential, vacuum, air loaded and pilot operated.

The sliding gate seat is a remarkably

simple concept - it is made up of two primary parts: a movable disc and stationary plate with multiple orifices. Together, this seat set achieves levels of performance, reliability and accuracy that are superior to other valve designs.





● Optimized spring ranges for increased accuracy

● Jorlon diaphragm - excellent for high cycling, chemical resistance, and steam service. Optional metal diaphragm for higher temperature applications

● Stainless steel internals extend seat and trim life

● A range of easily exchanged Kvs (Cvs) are available depending on size

● Proprietary Jorcote coating delivers very low friction with outstanding wear resistance and a temperature rating of up to 288°C (550°F)

● Sliding gate seats provide

- Straight-through flow for reduced turbulence and quiet operation
- Short stroke for fast response and accurate control
- Easily interchangeable Kv's (Cv's)
- Tight shutoff due to overlap of seat closure area

1 SLIDING GATE PRESSURE REGULATORS

MK60

Self-Operated, Jorlon Diaphragm

The Mark 60 Series handles a broad range of applications including steam, water, oil, gas, air and chemicals. It is a self-operating pressure regulator used to regulate the downstream pressure to a predetermined setpoint. The sliding gate seats offer excellent control and extreme longevity in a compact, lightweight design.

Sizes	DN8 - DN100 (1/4" - 4")
Kv (Cv)	up to 172 (up to 200)
Diaphragm	Jorlon, Stainless Steel, Hastelloy C, Alloy 20
Setpoint	MK60: 0,07 to 15,2 bar (1 to 220 psi); MK60HP: 5,2 to 31 bar (75 to 450 psi)
Body Material	Ductile Iron, Bronze, Carbon Steel, Stainless Steel, Cast Iron
End Connection	Threaded, Flanged, Socket Weld, Butt Weld



MK601/602

Self-Operated, High Flow

The Mark 601 and Mark 602 Series are used in applications that require a higher Kv (Cv) rating without using a larger valve. The high flow Mark 601 has Kv's (Cv's) as high as 43 (50) and the super high flow Mark 602 has Kv's (Cv's) up to 60 (70). The sliding gate seats help reduce the droop commonly associated with high flow regulators.

Sizes	DN40 - DN50 (1-1/2" - 2")
Kv (Cv)	up to 60 (up to 70)
Diaphragm	Jorlon, Stainless Steel, Buna-N, Viton
Setpoint	1,4 to 11,0 bar (20 to 160 psi)
Body Material	Ductile Iron, Bronze, Carbon Steel, Stainless Steel
End Connection	Threaded, ANSI Flanges (150#, 300#), DIN Flanges (PN 10/16, PN25/40)

MK61

High Sensitivity

The Mark 61 Series handles a broad range of applications including steam, water, oil, gas, air and chemicals. It is a self-operating pressure regulator used to regulate the downstream pressure to a predetermined setpoint. The sliding gate seats offer excellent control and extreme longevity in a compact, lightweight design. It features a larger diaphragm to provide greater sensitivity.

Sizes	DN8 - DN20 (1/4" - 3/4")
Kv (Cv)	up to 3,8 (up to 4.4)
Diaphragm	Stainless Steel, Elastomer
Setpoint	0,07 to 12,4 bar (1 to 180 psi)
Body Material	Ductile Iron, Bronze, Carbon Steel, Stainless Steel
End Connection	Threaded, Flanged, Socket Weld, Butt Weld



MK63/64

Differential, Jorlon Diaphragm

The Mark 63 is designed to maintain a constant differential between the pressure on the discharge side of the regulator and the signal pressure loaded on the diaphragm. The Mark 64 provides the same flow capacity but with less offset in controlled pressure due to a larger diaphragm. This series is ideal in fuel oil atomization applications. A negative differential version is also available.

Sizes	MK63: DN8 - DN50 (1/4" - 2") MK64: DN8 - DN20 (1/4" - 3/4")
Kv (Cv)	up to 25,8 (up to 30)
Diaphragm	Jorlon, Stainless Steel, Buna-N, Viton
Setpoint	MK63: 0,07 to 15,2 bar (1 to 220 psi); MK64: 0,07 to 12,4 bar (1 to 180 psi)
Body Material	Ductile Iron, Bronze, Carbon Steel, Stainless Steel
End Connection	Threaded, Flanged, Socket Weld, Butt Weld
Options	Double Diaphragm, Flow through Dome, and Handwheel

1 SLIDING GATE PRESSURE REGULATORS

MK65

Downstream Vacuum Regulators

The Mark 65 Series is ideal for steam, water, oil, gas, air and chemical services. The vacuum regulators control very accurately and shutoff tightly to maintain the proper vacuum setting. They are used to maintain vacuums at predetermined settings and to regulate vacuums on evaporators, cookers, grinding fixtures, milling machines, altitude chambers and other vacuum systems.

Sizes	DN15 - DN50 (1/2" - 2")
Kv (Cv)	up to 25,8 (up to 30)
Diaphragm	Jorlon, Stainless Steel, Buna-N, Viton
Vacuum Range	0,035 to 0,886 kg/cm ² vacuum (1" Hg to 25" Hg)
Body Material	Ductile Iron, Bronze, Carbon Steel, Stainless Steel
End Connection	Threaded, Flanged, Socket Weld, Butt Weld



MK66

Dome Loaded, High Accuracy

The Mark 66 Series is a highly accurate and economical air loaded pressure regulator that provides regulation from a local station or from a remote station. Dome loading combined with the sliding gate seats provide excellent regulation and rangeability. This valve can be coupled with an extended range I/P for remote operation. It can also be manually controlled with a MK12 loading station or a LowFlow JR regulator.



Sizes	DN15 - DN150 (1/2" - 6")
Kv (Cv)	up to 340 (up to 395)
Diaphragm	Jorlon, Stainless Steel, Buna-N, Viton
Setpoint	up to body ratings
Body Material	Ductile Iron, Bronze, Carbon Steel, Stainless Steel, Cast Iron
End Connection	Threaded, Flanged, Socket Weld, Butt Weld

MK6769

Pilot-Operated, High Flow

The Mark 67 Series is for critical pressure reducing applications and provides greater accuracy and lower offset than can be achieved with a self-operated regulator. The sliding gate seats provide unsurpassed seat and diaphragm life, ease of installation, simplified maintenance and more accurate performance.

Sizes	DN15 - DN150 (1/2" - 6")
Kv (Cv)	up to 340 (up to 395)
Diaphragm	Stainless Steel, Monel, Hastelloy C, Alloy 20
Setpoint	0,69 to 13,8 bar (10 to 200 psi)
Body Material	Ductile Iron, Carbon Steel, Stainless Steel, Cast Iron
End Connection	Threaded, Flanged, Socket Weld, Butt Weld



MK675

Wafer Style, Jorlon Diaphragm

The Mark 675 Series wafer style sliding gate pressure regulator is used to regulate the downstream pressure to a predetermined setpoint. The wafer style design allows for easy installation and maintenance due to its reduced weight and sliding gate seats. The flow is straight through the valve seats and body. Direction of the disc travel is perpendicular to the flow, not opposed to the direction of the flow. The MK675 can use a wider range of its stroke to give accurate control; less offset.

Sizes	DN80 - DN150 (3" - 6")
Kv (Cv)	up to 345 (up to 400)
Diaphragm	Jorlon, EPDM, Neoprene/Nylon, Viton, Buna-N
Setpoint	0,48 to 2,41 bar (7 - 35 psi)
Body Material	Carbon Bar, Carbon Steel, Stainless Steel Bar, Stainless Steel
Options	Closing Cap, Handwheel (Range Options), Bleed Port, Stainless Bolting, Clean for Oxygen or Oil-Free Service

1 SLIDING GATE BACK PRESSURE REGULATORS

MK50

Self-Operated, Jorlon Diaphragm

The Mark 50 Series handles a broad range of applications including steam, water, oil, gas, air and chemicals. Excellent capacity and the sliding gate trim enables the Mark 50 to quickly and accurately regulate upstream pressure, preventing over-pressure situations.

Sizes	DN8 - DN100 (1/4" - 4")
Kv (Cv)	up to 172 (up to 200)
Diaphragm	Jorlon, Stainless Steel, Buna-N, Viton
Setpoint	MK50: 0,03 to 10,3 bar (0.5 to 150 psi) MK50HP: 5,2 to 31,0 bar (75 to 450 psi)
Body Material	Ductile Iron, Bronze, Carbon Steel, Stainless Steel, Cast Iron
End Connection	Threaded, Flanged, Socket Weld, Butt Weld



MK501/502

High Flow, Super High Flow

The Mark 501 and Mark 502 Series are used in applications that require a higher Kv (Cv) rating without using the next highest line size. The high flow Mark 501 has Kv's (Cv's) as high as 43 (50) and the super high flow Mark 502 has Kv's (Cv's) up to 60 (70). The sliding gate seats help reduce the build-up commonly associated with high flow back pressure regulators.

Sizes	DN40 - DN50 (1-1/2" - 2")
Kv (Cv)	up to 60 (up to 70)
Diaphragm	Jorlon, Stainless Steel, Buna-N, Viton
Setpoint	0,03 to 10,3 bar (0.5 to 150 psi)
Body Material	Ductile Iron, Bronze, Carbon Steel, Stainless Steel
End Connection	Threaded, Flanged, Socket Weld, Butt Weld

MK51

High Sensitivity

The Mark 51 Series handles a broad range of applications including steam, water, oil, gas, air and chemicals. Excellent capacity and the sliding gate trim enables the Mark 51 to quickly and accurately regulate upstream pressure, preventing over-pressure situations. It features a larger diaphragm to provide greater sensitivity.

Sizes	DN8 - DN20 (1/4" - 3/4")
Kv (Cv)	up to 3,8 (up to 4.4)
Diaphragm	Stainless Steel, Elastomer
Setpoint	0,03 to 11,7 bar (0.5 to 170 psi)
Body Material	Ductile Iron, Bronze, Carbon Steel, Stainless Steel
End Connection	Threaded, Flanged, Socket Weld, Butt Weld



MK53/54

Differential, Jorlon Diaphragm

The Mark 53 is designed to maintain inlet pressure at a set differential pressure over the signal pressure loaded on the diaphragm. The Mark 54 provides the same flow capacity but with less offset in controlled pressure due to a larger diaphragm. It can be used for both differential and remotely adjusted applications. A negative differential version is also available.

Sizes	MK53: DN8 - DN50 (1/4" - 2") MK54: DN8 - DN20 (1/4" - 3/4")
Kv (Cv)	up to 25,8 (up to 30)
Diaphragm	Jorlon, Stainless Steel, Buna-N, Viton
Setpoint	Mark 53: 0,03 to 10,3 bar (0.5 to 150 psi) Mark 54: 0,03 to 11,7 bar (0.5 to 170 psi)
Body Material	Ductile Iron, Bronze, Carbon Steel, Stainless Steel
End Connection	Threaded, Flanged, Socket Weld, Butt Weld
Options	Double Diaphragm, Flow through Dome, and Handwheel

1 SLIDING GATE BACK PRESSURE REGULATORS

MK55

Upstream Vacuum, Jorlon Diaphragm

The Mark 55 Series control very accurately and shutoff tightly to maintain the proper vacuum setting. They are used to maintain vacuums at predetermined settings and to regulate vacuums on evaporators, cookers, grinding fixtures, milking machines, altitude chambers and other vacuum systems.

Sizes	DN8 - DN50 (1/4" - 2")
Kv (Cv)	up to 25,8 (up to 30)
Diaphragm	Jorlon, Stainless Steel, Buna-N, Viton
Vacuum Range	0,035 to 0,886 kg/cm ² vacuum (1" Hg to 25" Hg)
Body Material	Ductile Iron, Bronze, Carbon Steel, Stainless Steel
End Connection	Threaded, Flanged, Socket Weld, Butt Weld



MK56

Dome Loaded, High Accuracy

The Mark 56 Series is a highly accurate and economical air loaded back pressure regulator that provides regulation from a local station or from a remote station. The Mark 56 requires no control spring or pilot. Instead, a static air signal is applied to the top of the diaphragm to determine the setpoint. This valve can be coupled with an extended range I/P for remote operation. It can also be manually controlled with a MK12 loading station or a LowFlow JR regulator.



Sizes	DN15 - DN150 (1/2" - 6")
Kv (Cv)	up to 340 (up to 395)
Diaphragm	Jorlon, Stainless Steel, Buna-N, Viton
Setpoint	up to body ratings
Body Material	Ductile Iron, Bronze, Carbon Steel, Stainless Steel, Cast Iron
End Connection	Threaded, Flanged, Socket Weld, Butt Weld

MK57

Pilot-Operated, Superior Accuracy

The Mark 57 Series pilot-operated back pressure regulator is designed to accurately control pressure to 90% of its rated flow capacity with only a small deviation from setpoint. The Mark 57 provides accuracy that approaches that of controller-operated valves and should be considered on most critical applications.

Sizes	DN15 - DN150 (1/2" - 6")
Kv (Cv)	up to 340 (up to 395)
Diaphragm	Stainless Steel
Setpoint	0,7 to 12,8 bar (10 to 185 psi)
Body Material	Ductile Iron, Carbon Steel, Stainless Steel, Cast Iron
End Connection	Threaded, Flanged, Socket Weld, Butt Weld



MK575

Wafer Style, Jorlon Diaphragm

The Mark 575 Series wafer style sliding gate back pressure regulator is used to regulate the upstream pressure to a predetermined setpoint. The spring in the Mark 575 holds the sliding gate seats in their normally closed position. The wafer style design allows for easy installation and maintenance due to its reduced weight and sliding gate seats.

Sizes	DN80 - DN150 (3" - 6")
Kv (Cv)	up to 345 (up to 400)
Diaphragm	Jorlon, EPDM, Neoprene/Nylon, Viton, Buna-N
Setpoint	0,28 to 2,07 bar (4 - 30 psi)
Body Material	Carbon Bar, Carbon Steel, Stainless Steel Bar, Stainless Steel
Options	Handwheel (In Range), Stainless Bolting, Clean for Oxygen or Oil-Free Service

2

TEMPERATURE REGULATORS

For accurate temperature control - count on Jordan Valve and the entire Mark 80 Series product line.

Whether your application is tank heating, steam tracing, heat exchanging, air drying or regulated cooling, our regulators will maintain temperature without the need for external power or additional

instrumentation.

There are three key components to our temperature regulators: the sensing bulb, the stainless steel welded actuator and the sliding gate seats. You can expect accurate mechanical temperature control and proven reliability every time you use any of our temperature regulators.





● Custom capillary lengths up to 100 feet (30 meters)

● Variety of thermal fills allow for temperature control from -29°C (-20°F) to 232°C (450°F)

● Stainless Steel diaphragm eliminates failure caused by metal fatigue, the most common failure in bellows actuators

● The upper and lower casings and diaphragm are heliarc welded around the circumference to fuse a solid bond eliminating the need for a gasket - a common source for leakage

● A variety of sensing bulbs available

● Sliding gate seats have a shorter stroke than globe valves, thus the temperature span (the number of degrees from full open to just closed) is as low as 4°C (8°F)

- Sliding gate seats provide
 - Straight-through flow for reduced turbulence and quiet operation
 - Short stroke for fast response and accurate temperature control
 - Easily interchangeable Cv's (Kv's)
 - Tight shutoff due to overlap of seat closure area

2 TEMPERATURE REGULATORS



MK80

Self-Operated, No External Power Source

The Mark 80 Series is completely self-operated and requires no external power source or other expensive instrumentation to operate the valve. Depending on valve action, the seats open or close as bulb senses rise in temperature. The Mark 80 has high rangeability - controls flows from 10% to 90% of rated capacity. Available with up to 30 meters (100 feet) in capillaries.

Sizes	DN8 - DN50 (1/4" - 2")
Body Material	Ductile Iron, Bronze, Carbon Steel, Stainless Steel
End Connection	Threaded, Flanged, Socket Weld, Butt-Weld
Kv (Cv)	up to 26 (up to 30)
Seat Material	Jorcote
Control Range	-29°C (-20°F) to 232°C (450°F)

MK801/802

Self-Operated, High Flow

The Mark 801/802 Series is completely self-operated and requires no external power source or other expensive instrumentation to operate the valve. The Mark 801/802 Series are high-flow versions of our Mark 80 Series temperature regulators. Available with up to 30 meters (100 feet) in capillaries.

Sizes	DN15 - DN50 (1/2" - 2")
Body Material	Ductile Iron, Bronze, Carbon Steel, Stainless Steel
End Connection	Threaded, Flanged, Socket Weld, Butt-Weld
Kv (Cv)	up to 60 (up to 70)
Seat Material	Jorcote
Control Range	-29°C (-20°F) to 163°C (325°F)

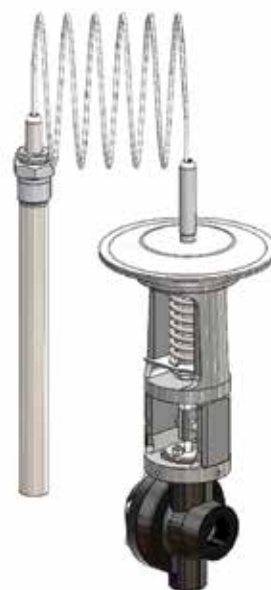

MK85

Controlled Failure Option

The Mark 85 Series is a self-operated temperature regulator with controlled failure option which allows you to predetermine the position of the valve in the event of a thermal system failure. The Mark 85 is designed to fail closed on heating applications and to fail open on cooling applications. The Mark 85 Series is ideal for slower responding systems such as autoclaves and large storage tanks.

Sizes	DN8 - DN20 (1/4" - 3/4")
Body Material	Ductile Iron, Bronze, Carbon Steel, Stainless Steel
End Connection	Threaded, Flanged, Socket Weld, Butt-Weld
Kv (Cv)	up to 3,8 (up to 4.4)
Seat Material	Jorcote
Control Range	4°C (40°F) to 141°C (285°F)



MK86

Ambient Temperature

The Mark 86 regulator is designed to control steam tracing lines based on ambient temperatures. The MK86 allows steam to flow through the tracer lines only when it is needed, then opens or closes when ambient temperature rises above or below the setpoint depending up action.

Sizes	DN15 - DN50 (1/2" - 2")
Body Material	Ductile Iron, Bronze, Carbon Steel, Stainless Steel
End Connection	Threaded, Flanged, Socket Weld, Butt-Weld
Kv (Cv)	up to 25,8 (up to 30)
Seat Materials	Jorcote
Control Range	-15°C (5°F) to 99°C (210°F)

MK87

Externally Piloted

The Mark 87 piloted temperature regulator is the sliding gate valve engineered to provide wide rangeability, and greater accuracy, for a variety of temperature control applications. Designed with the same technology as the Mark 80, the Mark 87 is a piloted temperature regulator that offers quality and performance. It can be used where larger line sizes and higher flow rates are required.

Sizes	DN15 - DN150 (1/2" - 6")
Body Material	Ductile Iron, Carbon Steel, Stainless Steel, Cast Iron
End Connection	Threaded, Flanged, Socket Weld, Butt-Weld
Kv (Cv)	up to 340 (up to 395)
Seat Materials	Jorcote
Control Range	-29°C (-20°F) to 232°C (450°F)

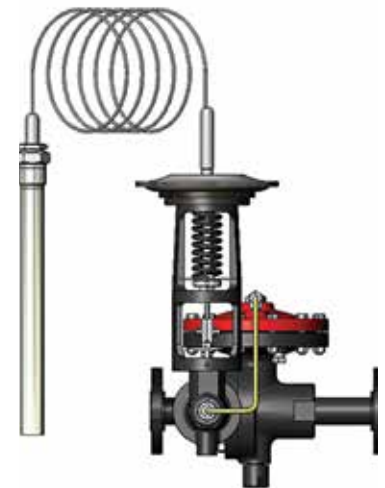

MK89/89MX

Three-Way, Diverting or Mixing Service

The Mark 89 is used for diverting service and is ideal for bypassing fluids around coolers or filters. In this configuration, there is one inlet and two outlets. As one outlet closes, the other outlet opens, diverting flow from one channel to the other. The Mark 89MX is ideal for mixing service.

Sizes	DN0 - DN50 (1-1/2" - 2")
Body Material	Carbon Steel, Stainless Steel
End Connection	Threaded, Socket Weld, Flanged
Kv (Cv)	up to 25,8 (up to 30)
Seat Materials	Jorcote
Control Range	-29°C (-20°F) to 232°C (450°F)

3

TANK BLANKETING & GAS REGULATORS

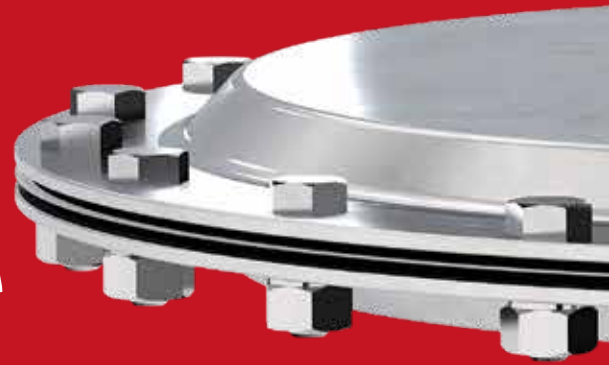

Jordan Valve tank blanketing and gas valves ensure that a constant gas pressure is maintained in the vapor space of a storage tank.

Whether your application is chemical, petrochemical, oil & gas, water & waste water treatment, or food & beverage,

count on Jordan Valve's tank blanketing valves to offer the perfect solutions.

A wide range of gas and tank blanketing valves are available including self-operated or pilot-operated, internally sensed, balanced plug, double seated or pilot operated.

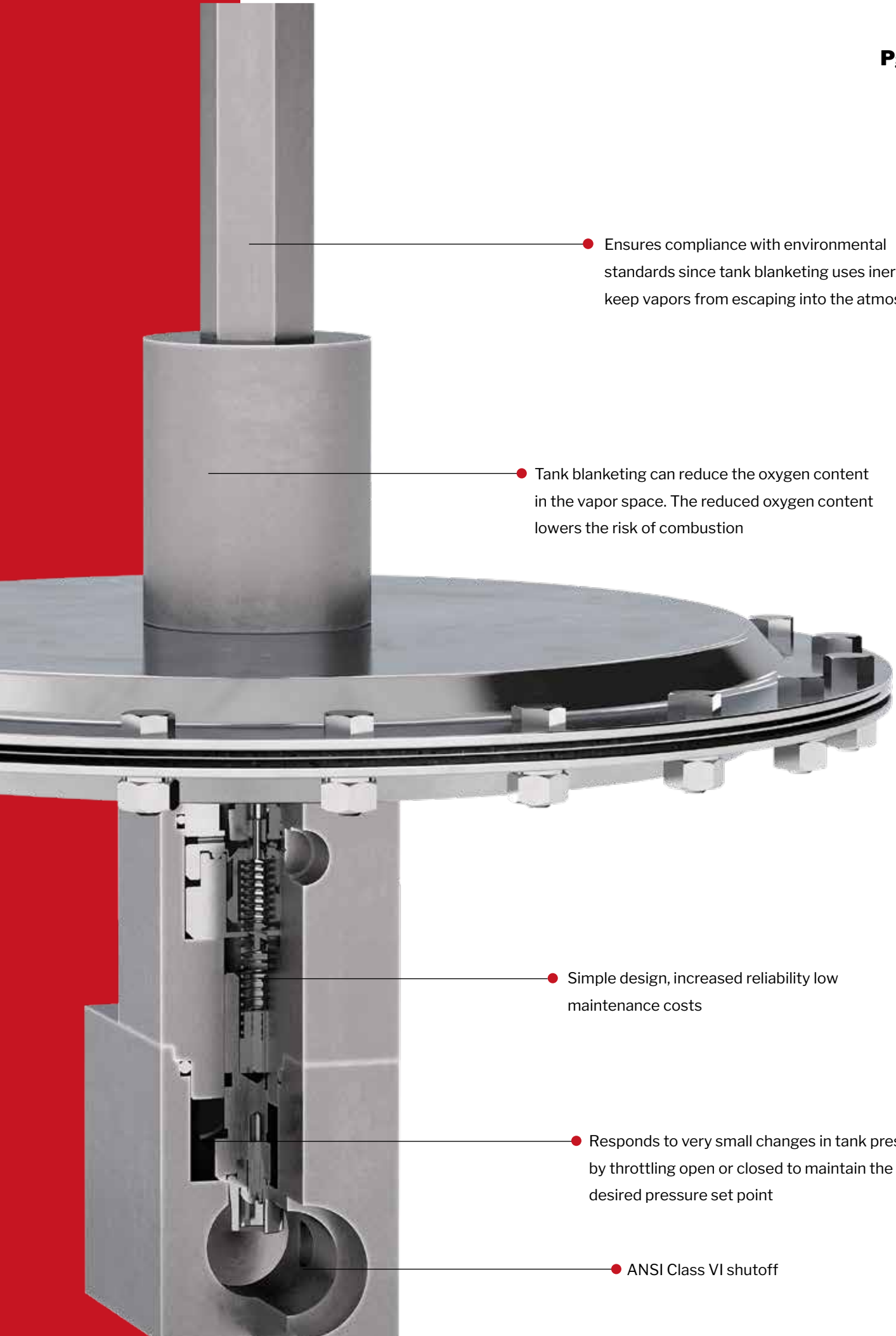

● Ensures compliance with environmental standards since tank blanketing uses inert gas to keep vapors from escaping into the atmosphere

● Tank blanketing can reduce the oxygen content in the vapor space. The reduced oxygen content lowers the risk of combustion

● Simple design, increased reliability low maintenance costs

● Responds to very small changes in tank pressure by throttling open or closed to maintain the desired pressure set point

● ANSI Class VI shutoff

3 TANK BLANKETING & GAS REGULATORS

MK608

Gas Pressure Regulator, Balanced Plug



The Mark 608 gas pressure regulator is used on large tank blanketing applications or other low pressure gas regulation. In a tank blanketing application, the Mark 608 is used to control the flow of the blanketing gas into the tank to maintain the proper positive pressure. Once the blanket has been established, a small flow of nitrogen is continually admitted to the tank to keep the blanket fresh.

Sizes	DN40 - DN50 (1-1/2" - 2")
Body Material	Bronze, Carbon Steel, Stainless Steel
End Connection	Threaded, Flanged
Diaphragm	Buna-N/Nylon, Viton/Nomex, EPDM with Polyester Reinforcement
Setpoint	5,0 mbar to 0,34 bar (2" w.c. to 5 psi)
Max Inlet Pressure	4 bar (60 psi)

MK608IS

Gas, Low Pressure, Internal Sensing

The Mark 608IS gas pressure regulator is the ideal valve for low pressure gas regulation. The self-contained low pressure gas regulator is for use on tank blanketing, gas meter inlet pressure regulating, gas burners and other low pressure air and gas applications. The valve can be installed in any position and can be easily repositioned in-line.

Sizes	DN20 - DN32 (3/4" - 1-1/4")
Body Material	Carbon Steel, Stainless Steel
End Connection	Threaded, Flanged
Diaphragm	Viton
Setpoint	2,5 mbar to 0,24 bar (1" w.c. to 3.5 psi)
Max Inlet Pressure	10 bar (150 psi)



MK608BP

Balanced Plug, ANSI Class VI



The Mark 608BP balanced plug gas pressure regulator is the ideal valve for low pressure gas regulation with higher inlet pressures. The self-contained low pressure gas regulator is for use on tank blanketing, gas meter inlet pressure regulating and other low pressure air and gas applications. The valve can be installed in any position and can be easily repositioned in-line.

Sizes	DN20 - DN25 (3/4" - 1")
Body Material	Ductile Iron, Carbon Steel, Stainless Steel
End Connection	Threaded, Flanged
Diaphragm	Buna-N/Nylon (DI body); Viton (CS & SS body)
Setpoint	5,0 mbar to 0,24 bar (2" w.c. to 3.5 psi)
Max Inlet Pressure	10 bar (150 psi)

MK688

Piloted Soft Seat Regulators, ANSI Class VI

The Mark 688 Series piloted soft seat regulator is designed specifically to provide accurate pressure control on very low pressure tank blanketing systems. The pilot operated Mark 688 responds to very small changes in tank pressure by throttling open or closed to maintain the desired pressure set point.

Sizes	DN25 - DN50 (1" - 2")
Body Material	Carbon Steel, Stainless Steel
End Connection	ANSI Flanges 150/300 #
Diaphragm	Buna-N
Kv (Cv)	DN: 25: 14,7; DN40: 26,0; DN50: 38,9 (1": 17; 1-1/2": 30 ; 2": 45)
Max Inlet Pressure	13,8 bar (200 psi)



MK695

Piloted, Very Low Set Points

The Mark 695 Series piloted soft seat regulator is designed specifically to provide accurate pressure control on very low pressure tank blanketing systems. The pilot operated Mark 695 responds to very small changes in tank pressure by throttling open or closed to maintain the desired pressure set point.

Sizes	DN20, DN25 (3/4", 1")
Body Material	Carbon Steel, Stainless Steel
End Connection	NPT, ANSI Flanges 150#, 300#
Diaphragm	Teflon Sheet
Kv (Cv)	0,86; 1,73; 3,5; 6,5; 8,7 (1, 2, 4, 7.5, 10)
Max Inlet Pressure	13,8 bar (200 psi)

3 TANK BLANKETING & GAS REGULATORS



MK695

Gas Regulators, DN50, Internally Piloted

The DN50 Mark 695 is an internally piloted tank blanketing regulator. Pre-formed Jorlon is used for the diaphragm for maximum sensitivity to minute pressure changes inside the tank. Optional features include: inline or angle bodies, purge system and outlet gauges.

Sizes	DN50 (2")
Body Material	Carbon Steel, 316L
End Connection	Threaded, Flanged, Socket Weld, Butt Weld
Diaphragm	Pre-formed Jorlon
Flow Capacity Kv (Cv)	8,6 (10); 16,3 (19), 24,1 (28), 41,3 (48)
Set Pressure	1,25 mb - 13,4 mb (0.5 - 5.4 wc); 9,96 mb - 44,8 mb (4 - 18 wc)

MK695X

Small Tanks, Accurate Pressure Control

The Mark 695X Series regulator is designed specifically to provide accurate pressure control on very low pressure tank blanketing systems. The Mark 695X responds to very small changes in tank pressure by throttling open or closed to maintain the desired pressure set point. It has an ultralight diaphragm for maximum sensitivity.

Sizes	DN15 - DN20 (1/2" - 3/4")
Body Material	316L Stainless Steel
End Connection	FNPT, ANSI & DIN Flanges
Diaphragm	Ultra Lightweight Teflon
Spring Ranges	1,25 mb - 13,7 mb (0.5 - 5.5 wc); 9,96 mb - 24,9 mb (4 - 10 wc)



MK508

Gas Back Pressure Regulator

The Mark 508 Series gas back pressure regulator is the ideal valve for low back pressure gas services. The Mark 508 works in conjunction with the Mark 608, in a low pressure tank blanketing valve system. The Mark 508 can be used to vent gas from the tank to prevent the blanketing pressure from rising to a level that could damage the tank while maintaining a small constant flow to keep the blanket fresh. It will also work well in any other type of low back pressure application.



Sizes	DN20 - DN50 (3/4" - 2")
Body Material	Carbon Steel, Stainless Steel
End Connection	Threaded, Flanged
Diaphragm	Viton
Max Inlet Pressure	1,7 bar (20 psi)

MK627

Gas Regulator, Self-Operated, High Inlet Pressure



The Mark 627 Series is a self-operated, pressure-reducing regulator and is designed to provide tight-shutoff and accurate regulation on low or high pressure systems. It can be used on air, natural gas or a variety of other gases. The top entry design allows for easy in-line maintenance.

Sizes	DN20, DN25, DN50 (3/4", 1", 2")
Body Material	Carbon Steel, Ductile Iron, Stainless Steel
End Connection	FNPT (contact factory for other options)
Diaphragm	Nitrile
Orifice Size	2mm (3/32"); 3mm (1/8"); 5mm (3/16"); 6mm (1/4"); 10mm (3/8"); 13mm (1/2") - interchangeable

MK630

Gas Regulator, Self-Operated, High Inlet Pressure

The Mark 630 Series is a self-operated pressure reducing regulator designed to provide tight shutoff and accurate regulation on high pressure gas systems. It can be used on air and a variety of gases. It is designed to handle inlet pressures up to 103 bar (1500 psi).

Sizes	DN25 & DN50 (1" & 2")
Body Materials	DN25: Carbon Steel (WCB A216); DN50: Ductile Iron
End Connection	FNPT (contact factory for other options)
Diaphragm	Neoprene, Viton
Orifice Sizes	3mm (1/8"); 5mm (3/16"); 6mm (1/4"); 10mm (3/8"); 13mm (1/2") - interchangeable



MK687

Piloted, Critical Pressure Reducing Applications



The Mark 687 Series is a piloted soft seat regulator for critical pressure reducing applications. It uses balance plug trim with the action of a pilot valve to create a faster, more accurate (meaning less droop as your flows increase) response.

Sizes	DN40 - DN50 (1-1/2" - 2")
Kv (Cv)	DN40: 34 (40); DN50: 43 (50)
Seat	316SS/PTFE
Body Material	Carbon Steel (ASME SA216 WCB) & Stainless Steel (ASME SA351 CF8M)
End Connection	Threaded & Flanged (ANSI 150#, 300# and DIN PN10/16, PN25/40)
Min&MaxPressure	1,7 bar minimum (25 psi); 10,3 bar maximum (150 psi)

4 GLOBE STYLE REGULATING VALVES



MK68G

Globe, High Capacity, Accurate

The Mark 68G offers high capacity, accurate regulation and easy servicing, making it the ideal choice for your industrial grade pressure reducing applications. The MK68G can be supplied with a hard seat for ANSI Class IV shutoff or a soft seat for ANSI Class VI shutoff. Easily removable bottom cap allows quick access for replacing seat and plug.

Sizes	DN8 - DN50 (1/4" - 2")
Body Material	Ductile Iron, Bronze, Carbon Steel, Stainless Steel
End Connection	Threaded, Flanged, Socket Weld
Diaphragm	Stainless Steel, Jorlon, Buna-N/Nylon, Viton/Nomex
Seat	Plug: Buna-N, Viton, Hardened 17-4 pH Stainless Steel, EPDM
Kv (Cv)	up to 16,3 (up to 19)

MK686G

Air-Loaded, Globe Trim, ANSI IV or VI

The Mark 686G features air-loading, high capacities, accurate regulation, and easy servicing, making it an exceptional choice for your pressure regulating applications. The Mark 686G has a large effective diaphragm area for increased accuracy and sensitivity along with large orifices and body passages which provides high flow capacities. Easily removable bottom cap allows quick access for replacing seat and plug.



Sizes	DN8 - DN50 (1/4" - 2")
Body Material	Carbon Steel, Stainless Steel, Ductile Iron, Bronze
End Connection	Threaded, Flanged
Diaphragm	Buna-N/Nylon, Stainless Steel, Viton/Nomex, Jorlon
Seat	Plug - Buna-N, Viton, Hardened 17-4 pH Stainless Steel, EPDM
Max Inlet Pressure	20,7 bar (300 psi)

MK58FT/A

Cage Trim, Dual Inlet & Outlet for Through-Flow

The Mark 58 Series features three ports: a bypass outlet on the bottom and two side ports which are directly connected to serve as dual inlet and outlet for through-flow. The Mark 58FT is designed to be installed in a "T" fashion such that the fluid normally flows in one side and out the other side; whereas the Mark 58A is designed to be installed with one side port as an inlet and the other side port plugged with the flow being relieved through the bottom bypass.



Sizes	DN8 through DN50 (1/4" through 2")
Body Material	Ductile Iron, Carbon Steel, Stainless Steel, Bronze
End Connection	Threaded, Flanged, Socket Weld
Diaphragm	Buna-N/, EPDM, Jorlon, 316/316L SST, Viton/Nomex
Kv (Cv)	up to 28,0 (up to 32.4)
Cage Materials	Electro-nickel plated steel or SS depending on body material

MK5108

Piloted, Back Pressure Regulating Valve



In many liquid piping systems, it is vital that line pressure is maintained within relatively narrow limits. Installed in the main flow line, the standard Mark 5108-2 acts as a back pressure or pressure sustaining valve. In this configuration, the valve maintains a constant upstream pressure regardless of fluctuating downstream demand. When used in a bypass line, the same model will function as a relief valve.

Sizes	1-1/4" - 24"
Body Materials	Ductile Iron, Cast Steel, Cast Bronze, Stainless Steel
End Connection	Flanged (#150, #300), Screwed, Grooved End
Diaphragm	Buna-N, Viton, EPDM
Max Inlet Pressure	51 bar (740 psi)

MK6127

Piloted, Liquid Pressure Regulating Valves

The Mark 6127 pressure-reducing valve is used in many applications worldwide. The primary function of the Mark 6127 is to reduce a greater upstream pressure to a lesser, more manageable downstream pressure, and operate without regard to either upstream supply or downstream demand. The valve is easily maintained without removal from the line.

Sizes	1-1/4" - 24"
Body Material	Ductile Iron, Cast Steel, Cast Bronze, Stainless Steel
End Connection	Flanged (#150, #300), Screwed, Grooved End
Diaphragm	Buna-N, Viton, EPDM
Max Inlet Pressure	51 bar (740 psi)



5

SLIDING GATE CONTROL VALVES

Whether you are trying to control pressure, temperature, level, Ph or flow rate, count on Jordan Valve sliding gate control valves. We can assist you with the proper control valve and the right accessories to meet the needs for your specific application. Our control valves are ideal for steam, utility, petroleum,

chemical refining and numerous other applications. The sliding gate seat design offers straight-through flow, short stroke and fast response, quiet operation, easily interchangeable Kv's (Cv's) and tight shut off. The simplistic design of the sliding gate valve makes maintenance easy to perform.

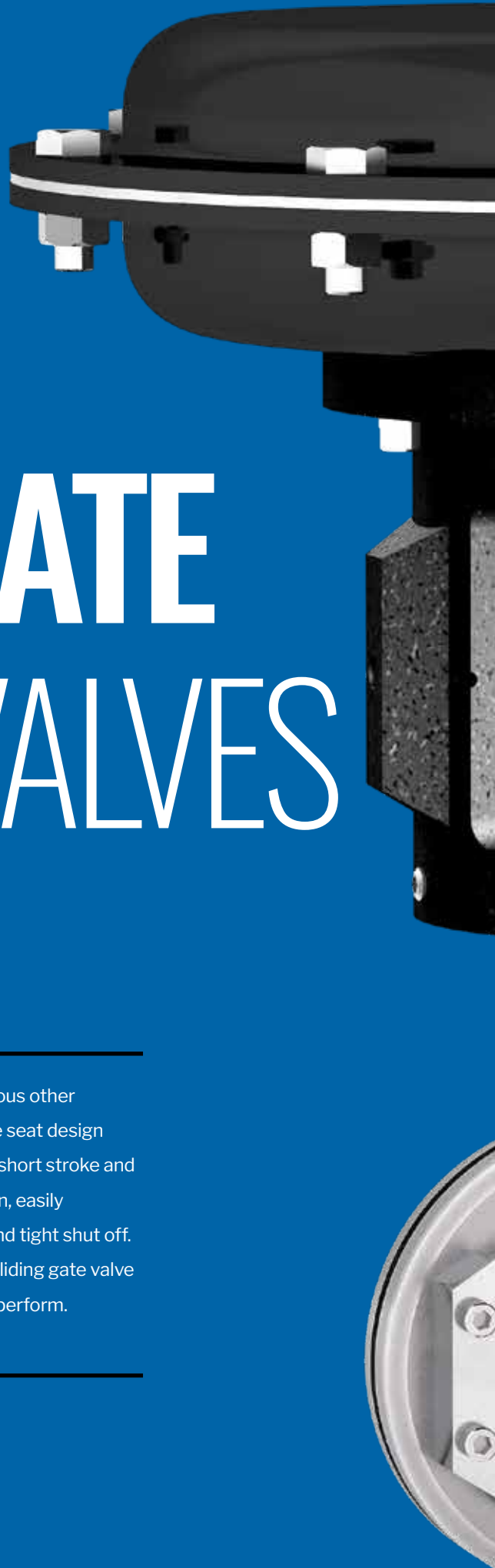

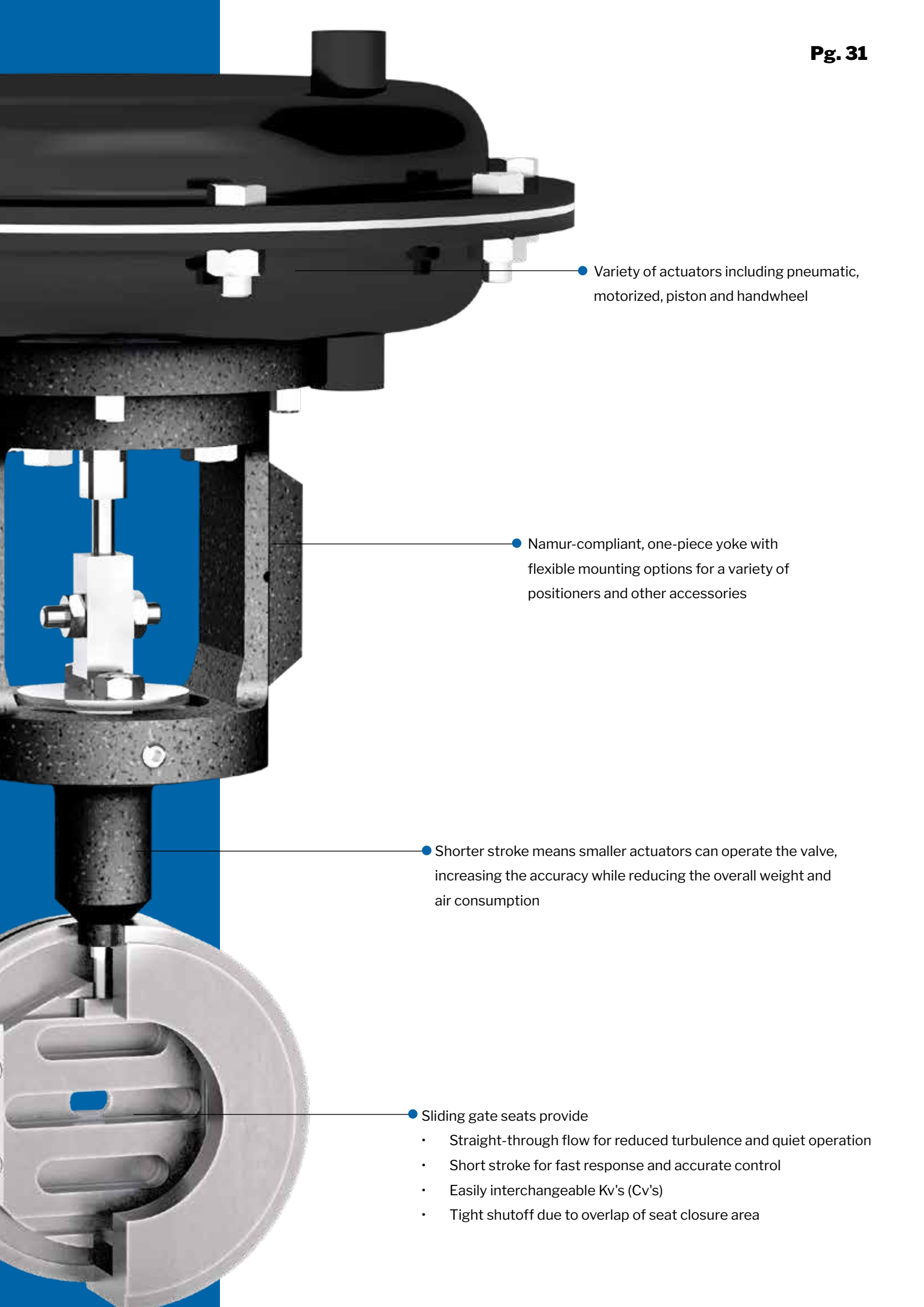

• Variety of actuators including pneumatic, motorized, piston and handwheel

• Namur-compliant, one-piece yoke with flexible mounting options for a variety of positioners and other accessories

• Shorter stroke means smaller actuators can operate the valve, increasing the accuracy while reducing the overall weight and air consumption

- Sliding gate seats provide
 - Straight-through flow for reduced turbulence and quiet operation
 - Short stroke for fast response and accurate control
 - Easily interchangeable Kv's (Cv's)
 - Tight shutoff due to overlap of seat closure area

5 SLIDING GATE CONTROL VALVES



MK70

Diaphragm Control Valve

The Mark 70 Series is a line of pneumatically-operated diaphragm control valves that combine multiple spring actuators with the precision of the sliding gate seat for closer control and greater accuracy. A side or top-mounted positioner is available to overcome the normal hysteresis for a control valve and actuator and to ensure that the valve stem position is always directly proportional to the control valve command signal.

Sizes	DN8 - DN50 (1/4" - 2")
Body Material	Ductile Iron, Carbon Steel, Stainless Steel, Bronze
Seat material	Jorcote on SST standard
Kv (Cv)	up to 26 (up to 30)
Action	Direct (ATC) or Reverse (ATO)
Ranges	0,2-1,0 bar; 0,4-2,1 bar (3-15 psi, 6-30 psi) or split ranges

MK701/702

High Flow, Higher Kvs (Cvs)

The Mark 701/702 high flow sliding gate control valve provides higher Kv (Cv) without going to a larger valve, straight through flow and ease of maintenance. A side or top-mounted positioner is available to overcome the normal hysteresis for a control valve and actuator and to ensure that the valve stem position is always directly proportional to the control valve command signal.

Sizes	DN15 - DN50 (1/2" - 2")
Body Material	Ductile Iron, Carbon Steel, Stainless Steel, Bronze
Seat material	Jorcote on SST standard
Kv (Cv)	up to 60,3 (up to 70)
Action	Direct (ATC) or Reverse (ATO)
Ranges	0,2-1,0 bar; 0,4-2,1 bar 3-15 psi, 6-30 psi) or split ranges



MK75

Wafer Style, Compact Size, Very Precise



The Mark 75 is a lightweight, compact wafer-style body that weighs 10 times less than a traditional valve. We manufacture the valves using less steel and other raw materials. The shipping size, weight, packaging waste and costs decrease dramatically. The Mark 75 uses fewer fossil fuels not only when it is built and shipped, but also less power in its day-to-day operations and fewer resources when it needs maintenance.

Sizes	DN25 - DN200 (1" - 8")
Body Material	Stainless Steel, Carbon Steel
Kv (Cv)	up to 519 (up to 600)
Ranges	0,2-1,0; 0,2-0,6*; 0,6-1,0*; 0,4-2,1 bar (3-15, 3-9*, 9-15*, 6-30 psi) * positioner required
Turndown Ratio	100:1
Shutoff	ANSI Class IV tightness



MK75HW

Wafer Style, Hand Operated, Precise Adjustment

The Mark 75HW is a manually operated, sliding gate control valve. The hand wheel operator allows the user to manually position the valve for optimum flow and lock in place. The Mark 75HW features a 'T' slot design connection to the disc. This connection allows for quick and easy reversing of functions. The valve can go from reverse acting to direct acting (or vice versa).

Sizes	DN25 - DN50 (1" - 2")
Body Material	316 Stainless Steel, Carbon Steel
Seat Materials	Jorcote/316SS standard
Kv (Cv)	up to 62 (up to 72)
Turndown Ratio Capability	100:1
Max Inlet Pressure	10 bar (150 psi)

MK75PTP

Piston Operated with Smart Positioner

The Mark 75PTP is a Mark 75 wafer style control valve with an 80mm stainless steel piston actuator. The Gemu cPOS smart positioner is standard and required for control applications. For on/off service, the valve may be supplied without a positioner. The JVCV should be used for sizing selection. The "T" slot design connection allows for quick and easy reversing of function - from reverse acting to direct acting (or vice versa).

Sizes	DN25 - DN50 (1" - 2")
Body Material	Stainless Steel, Carbon Steel
Max Pressure Drop	8,6 bar (125 psi) with standard piston actuator and spring
Ranges	DN25: 0,88 - 1,01 bar (12.7 - 14.7 psi) ; DN40: 0,88 - 1,15 bar (12.7 - 16.7 psi); DN50: 0,88 - 1,32 bar (12.7 - 19.1 psi)
Turndown Ratio	100:1
Shutoff	ANSI Class IV tightness



MK75MV

Wafer Style, Motor Operated, High Accuracy

The Mark 75MV is a lightweight, compact wafer-style body that weighs 10 times less than a traditional valve and comes standard with a motor valve. The motor can operate on 120 or 240 VAC with 24 VDC as an option. The Mark 75 uses fewer fossil fuels not only when it is built and shipped, but also less power in its day-to-day operations and fewer resources when it needs maintenance.

Sizes	DN25 - DN150 (1" - 6")
Body Material	Stainless Steel, Carbon Steel
Kv (Cv)	up to 345 (up to 400)
Ranges	4-20mA; 4-12mA; 12-20mA; 0-5 VDC; 0-10 VDC, On/Off
Turndown Ratio	100:1
Shutoff	ANSI Class IV tightness

5 SLIDING GATE CONTROL VALVES

MK33

Motor Operated, Electric Valve

The Mark 33 is a motor operated valve featuring the Jordan sliding gate seat and heavy-duty industrial motors for proportional (resistance), on-off, or 4-20 mA electronic format. The Mark 331/332 is the high flow version of this valve, and the Mark 337 is the equal percentage version. Optional spring return available.

Sizes	DN8 - DN50 (1/4" - 2")
Body Material	Carbon Steel, Stainless Steel, Ductile Iron, Bronze
End Connection	Threaded, Flanged, Socket Weld, Butt-Weld
Kv (Cv)	MK 33: up to 26 (up to 30); MK331: up to 43 (up to 50); MK332: up to 61 (up to 70)
Seat Material	Jorcote
Command Signals	Proportional (resistance), on/off, 4-20mA or 2-10 VDC



MK37

Final Control Element Valves

The Mark 37 is a motor-operated control valve that combines a state-of-the-art electronic linear actuator with the exceptional performance of Jordan's sliding gate seat design. The result is a superior degree of accuracy that makes it ideal for use as the final control element in distributed process control systems. The Mark 371/372 is the high flow version and the Mark 377 is the equal percentage version.



Sizes	DN8 - DN150 (1/4" - 6")
Body Material	Carbon Steel, Stainless Steel, Ductile Iron, Cast Iron, Bronze
End Connection	Threaded, Flanged, Socket Weld, Butt-Weld
Kv (Cv)	up to 340 (up to 395)
Seat Material	Jorcote
Command Signals	Current or voltage command, on/off

MK74

Bellows Seal, Minimal Movement

The Mark 74 provides exceptional bellows life with a valve stroke that is just a fraction of that of other rising stem valves. This means Jordan Valve can use a smaller formed bellows that has minimal movement during operation.

Sizes	DN8 - DN50 (1/2" - 2")
Body Material	Carbon Steel, Stainless Steel, Ductile Iron, Bronze
Seat Materials	Jorcote/316SS
Kv (Cv)	up to 10 (up to 30)
Action	Direct (ATC) or Reverse (ATO)
Ranges	0,2-1,0 bar; 0,4-2,1 bar (3-15 psi, 6-30 psi) or split ranges



MK79/79MX

Three-Way, Bypass or Mixing

The Mark 79 is a pneumatic three-way control valve for use in either bypass or mixing service. The Mark 79 utilizes the unique sliding gate trim design to provide excellent control with superior longevity. Each valve contains two sets of sliding gate seats connected to a common valve stem for synchronized movement, whether in by-pass or mixing mode.

Sizes	DN40 & DN50 (1-1/2" & 2")
Body Material	Carbon Steel, Stainless Steel
End Connection	Flanged, Threaded
Kv (Cv)	up to 26 (up to 30)
Trim Material	Carbon Steel, Stainless Steel
Control Ranges	0,2-1 bar (3-15 psi); others upon request

6 GLOBE STYLE CONTROL VALVES

MK78

Globe Style, Accurate Performance

The Mark 78 is designed for accurate performance and simplified maintenance. This versatile product can be used on a variety of applications, including viscous/corrosive liquids, process gases or steam in process or utility service. The top entry cage design allows maintenance while the valve is in the line. Characterized flow options including linear, equal percentage, quick opening, or an equal-linear combination.



Sizes	DN15 - DN50 (1/2" - 2")
Body Material	Bronze, Carbon Steel, Stainless Steel
End Connection	Threaded, Flanged, Socket Weld, Butt-Weld
Kv (Cv)	up to 43 (up to 50)
Seat	ANSI Class IV (hard seat); ANSI Class VI Teflon (soft seat)
Control Ranges	0,2-1,0 bar; 0,4-2,1 bar (3-15 psi; 6-30 psi) or split ranges* * positioner required

MK2000

Angle Seat, On/Off

The Mark 2000 is an angle-seat valve with self-adjusting packing gland, intermediate relief and wiper. The angle-seat construction of the body makes possible extremely high flow rates, particularly in comparison to conventional globe valves.



Sizes	DN15 - DN50 (1/2" - 2")
Body Material	316SST
End Connection	Threaded (NPT)
Pressure Range	0 - 25 bar, max (0 - 362 psi)
Packing Materials	Spring loaded, PTFE-V Rings
Solenoid Options	125VAC or 24VDC

MK ED & ET

Single Port, Globe Style

The Mark ED and ET are single port, globe style bodies with composition or metal seats, and a balanced valve plug with "push down to close" action. The Mark ED is intended for general control applications over a wide variety of temperature and pressure drops. The Mark ET has a balanced tight shut off, and is used in applications requiring low leakage rates.

Sizes	1" - 8"
Pressure Classes	ASME Class 150, 300 and 600
End Connection	Raised Face or Ring Type Joint Flanges
Body Material	LCC, WCB, WCC, WC9, C5, Monel, CF8M (SST)
Flow Characteristic	Linear, Quick Opening or Equal Percentage
Shut off	Mark ET: Class IV & V; Mark ED: ANSI Class II & III



MK EZ

Globe Style, Quick Change Trim

The Mark EZ valves are globe style valves with integral end connections, post guiding and features quick change trim.

Sizes	1" - 4"
Pressure Classes	ASME Class 150, 300 and 600
End Connection	Raised Face or Ring Type Joint Flanges
Body Material	LCC, WCB, WCC, WC9, C5, Monel, CF8M (SST)
Flow Characteristic	Linear, Quick Opening or Equal Percentage
Shut off	Mark EWD: Class II, III & IV; Mark EWS: Class IV & V; Mark EWT: Class IV & V

6 GLOBE STYLE CONTROL VALVES

MK EW

Large Globe Style, Internal Flow Cavities

The Mark EW valve bodies are single port, globe style bodies with cage guiding, clamped seat rings and push down to close valve plug action. The series features large end connections and expanded internal flow cavities.

Sizes	8 x 6, 10 x 8, 12 x 6, 16 x 12, 20 x 16, 24 x 16, 24 x 20
Pressure Classes	ASME Class 150 through 900
End Connection	Raised Face, Ring Type Joint and Welded Flanges
Body Material	LCC, WCB, WCC, WC9, C5, Monel, CF8M (SST)
Flow Characteristic	Linear, Quick Opening or Equal Percentage
Shut off	Mark EWD: Class II, III & IV; Mark EWS: Class IV & V; Mark EWT: Class IV & V



MK HPX & HPAX

Globe & Angle

The Mark HPX is designed for high pressure applications in the process industry. Valves are cage guided, with metal seats and quick change trim. Balanced plugs are "push down to close". The Mark HPX is a straight globe valve while the HPAX is an angle valve. Percentage, quick opening, or an equal-linear combination.

Sizes	2", 3", 4", 6"
Pressure Classes	ASME 900 through 2500
End Connection	Raised Face, Ring Type Joint, Welded Flanges
Body Material	LCC, WCB, CF8M, CF3M, WCC
Flow Characteristic	Linear, Equal Percentage and Quick Opening
Shut off	Class II, III, IV & V

MK H900/H2500 Single Port, Globe Style

The Mark H2D is a single port, globe style body with cage guiding and balanced valve plug with "push down to close" action. Metal seat, piston rings are used to provide the seal between the valve plug and cage. The Mark H5T is a single port, globe style body with cage guiding, balanced valve plug, metal seat, and pressure assisted spring seal to provide the seal between the valve plug and cage.

Sizes	3", 4" & 6"
Pressure Classes	ASME 900 through 2500
End Connection	Raised Face, Ring Type Joint and Welded Flanges
Body Material	LCC, WCB, CF8M, CF3M, WCC
Flow Characteristic	Linear, Quick Opening or Equal Percentage
Shut off	Class II, III, IV & V



MK V-100

Rotary Control Valves

The Mark V-100 ball valve design utilizes a standard ball with a triangular shaped wedge formed in it. This design allows for both throttling control and on/off service used in conjunction with a variety of actuators.



Sizes	2" - 12"
Pressure Classes	ASME Class 150, 300 & 600
End Connection	Wafer Style (flangeless)
Body Material	LCC, WCB, CF8M (316SS)
Flow Characteristic	Modified Equal Percentage with forward flow into the convex side of the v-ball
Shut off	Class IV



www.jordanvalve.com

3170 Wasson Rd. Cincinnati, OH 45209 • jordan@richardsind.com

© JordanValve 2024 012/24